

A7-1341

ISSUE
E

IF IN DOUBT-ASK

FIRST W.O.

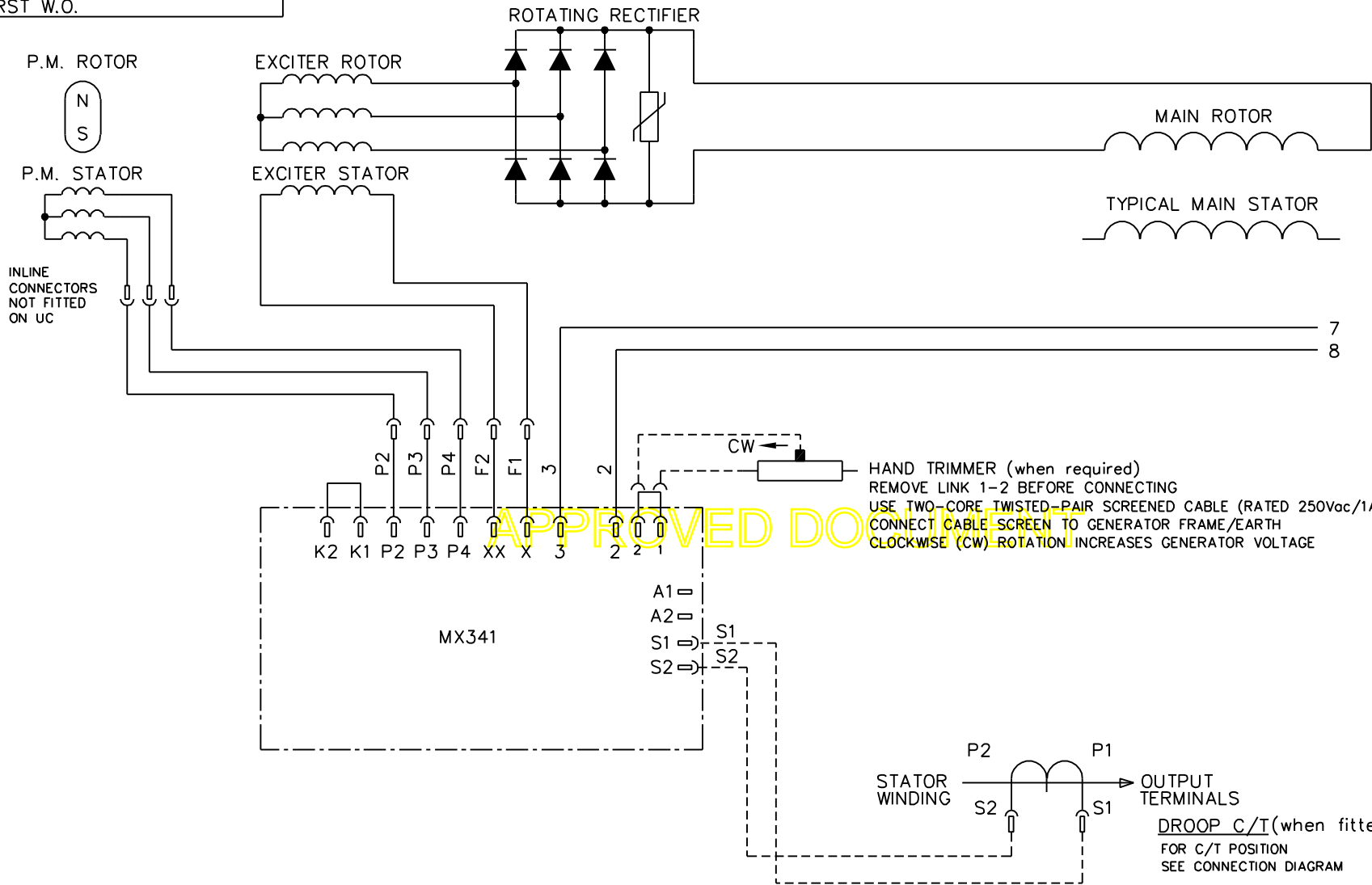

DETAILS OF THE MAIN STATOR AND MAIN TERMINAL CONNECTIONS ARE SHOWN ON SEPARATE WIRING DIAGRAM

BASE DIAGRAM

CERTIFIED PRINT	FRAME	---	OTHER FEATURES
(ONLY IF SIGNED)	CONTROL	SERIES MX341	
BY	POLES		
DATE	No. OF ENDS	---	
DRAWN SMH 09.06.99	SENSING	2 PHASE	
CHK'D PJW 17.10.06			A7-1341
APP'D DPC 17.10.06			ISSUE E
MOD.	ISS.	DRN.	DATE
			ALTERATION
			SHEET 1 OF 1 SHEETS

4-8664-01	E	USD	14.09.06	CHANGE OF COMPANY NAME
4/7377/8	D	AJB	02:11:04	INLINE CONNECTOR NOTE REMOVED, NOTE ADDED "INLINE CONNECTORS NOT FITTED ON UC"
4/6702/2	C	GTK	21.10.2004	HAND TRIMMER NOTE AMENDED
4/2461/2	B	SMH	09:06:99	ADDITIONAL TERMINAL '2' ADDED TO AVR, HAND TRIMMER CONNECTIONS REVISED
3/9120/1	A	P.N.	24:3:94	ORIGINAL ISSUE
MOD.	ISS.	DRN.	DATE	ALTERATION