

*This manual is to be given to  
the end user*

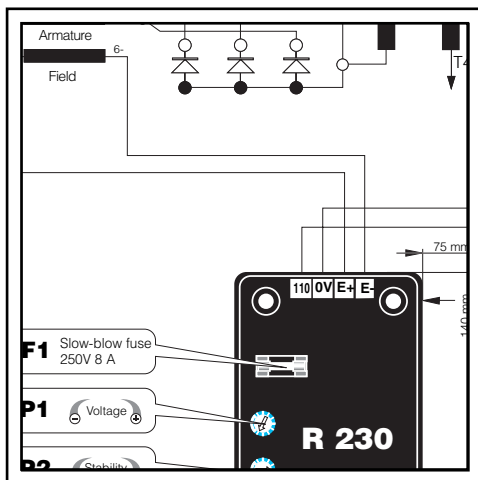

## R230

### A.V.R.

#### Installation and maintenance

**R230**  
**A.V.R.**

This manual concerns the alternator A.V.R. which you have just purchased.

We wish to draw your attention to the contents of this maintenance manual. By following certain important points during installation, use and servicing of your A.V.R., you can look forward to many years of trouble-free operation.

**SAFETY MEASURES**

Before using your machine for the first time, it is important to read the whole of this installation and maintenance manual.

All necessary operations and interventions on this machine must be performed by a qualified technician.

Our technical support service will be pleased to provide any additional information you may require.

The various operations described in this manual are accompanied by recommendations or symbols to alert the user to potential risks of accidents. It is vital that you understand and take notice of the following warning symbols.

**This A.V.R. can be incorporated in a machine marked C.E.**

**WARNING**

**Warning symbol for an operation capable of damaging or destroying the machine or surrounding equipment.**



**Warning symbol for general danger to personnel.**



**Warning symbol for electrical danger to personnel.**

Note: LEROY-SOMER reserves the right to modify the characteristics of its products at any time in order to incorporate the latest technological developments. The information contained in this document may therefore be changed without notice.

**R230****A.V.R.****CONTENTS**

|   |          |
|---|----------|
| <b>1 - SUPPLY .....</b>                       | <b>4</b> |
| 1.1 - SHUNT excitation system .....           | 4        |
| <b>2 - R230 A.V.R. ....</b>                   | <b>5</b> |
| 2.1 - Characteristics .....                   | 5        |
| 2.2 - R230 AVR option .....                   | 5        |
| <b>3 - INSTALLATION - COMMISSIONING .....</b> | <b>6</b> |
| 3.1 - Electrical checks on the AVR.....       | 6        |
| 3.2 - Settings.....                           | 6        |
| 3.3 - Electrical faults.....                  | 7        |
| <b>4 - SPARE PARTS .....</b>                  | <b>8</b> |
| 4.1 - Designation .....                       | 8        |
| 4.2 - Technical support service .....         | 8        |



**All such operations performed on the A.V.R. should be undertaken by personnel trained in the commissioning, servicing and maintenance of electrical and mechanical components.**

Copyright 2005 : MOTEURS LEROY-SOMER

This document is the property of :  
MOTEURS LEROY-SOMER

It may not be reproduced in any form without prior authorization.

All brands and models have been registered and patents applied for.

# R230 A.V.R.

## 1 - SUPPLY

### 1.1 - SHUNT excitation system

The alternator with Shunt excitation is self-excited with an R 230 voltage regulator.

The regulator monitors the exciter excitation current as a function of the alternator output voltage. Very simple in design, the alternator with shunt excitation has no sustaining short-circuit capacity.

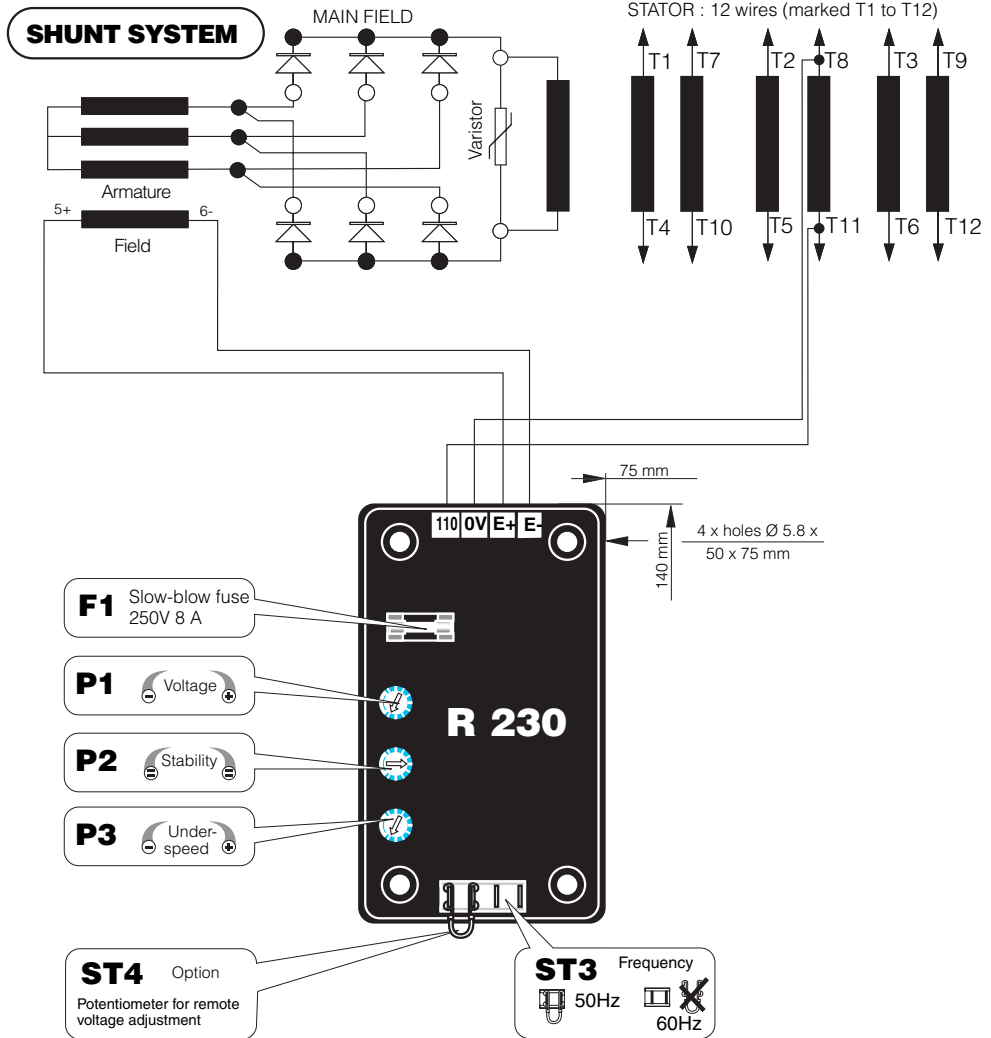

# R230

## A.V.R.

## 2 - R230 A.V.R.

### 2.1 - Characteristics

- Voltage regulation: around  $\pm 0.5\%$ .
  - Voltage supply/sensing range 85 to 139 V (50/60 Hz)
  - Rapid response time (500 ms) for a transient voltage variation amplitude of  $\pm 20\%$
  - Voltage setting **P1**
  - Stability setting **P2**.
- 
- Power supply protected by 8 A fuse, slow-blow action (tolerates 10 A for 10 s)
  - Frequency: 50 Hz with **ST3** jumper - 60 Hz without **ST3** jumper
  - Factory-set underspeed protection **P3**.

### 2.2 - R230 AVR option

- Potentiometer for remote voltage adjustment, 1000  $\Omega$  / 0.5 W min: adjustment range  $\pm 5\%$ .
- Remove the **ST4** jumper.

# R230

## A.V.R.

### 3 - INSTALLATION - COMMISSIONING

#### 3.1 - Electrical checks on the AVR

- Check that all connections have been made properly as shown in the attached wiring diagram.
- Check that the ST3 frequency selection jumper is on the correct frequency setting.
- Check whether the ST4 jumper or the remote adjustment potentiometer have been connected.

#### 3.2 - Settings



The machine is tested and set at the factory. When first used with no load, make sure that the drive speed is correct and stable (see the nameplate). After operational testing, replace all access panels or covers. The only possible adjustments to the machine should be made on the AVR.

#### 3.2.1 - R 230 settings (shunt system)

- Initial potentiometer settings
- **P1** potentiometer (AVR voltage adjustment): fully anti-clockwise.
  - Remote voltage adjustment potentiometer: centre position.
- Run the alternator at its rated speed. If the voltage does not increase, the magnetic circuit should be remagnetized (see section 2.3).
- Turn the AVR voltage adjustment potentiometer **P1** slowly until the output voltage rated value is obtained.
  - Adjust the stability setting using **P2**.
  - Sealed potentiometer **P3** is factory set at 48 Hz for 50 Hz and 58 Hz for 60 Hz

#### 3.2.2 - Special type of use

**WARNING**

**Excitation circuit E+, E- must not be left open when the machine is running : AVR damage will occur.**

#### 3.2.2.1 - R230 field weakening (SHUNT)

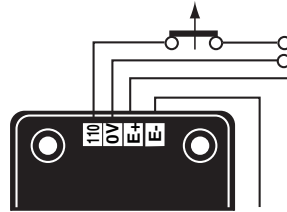

The exciter is switched off by disconnecting the AVR power supply (1 wire - 0 or 110V). Contact rating : 16A - 250V alt.

#### 3.2.2.2 - R230 field forcing

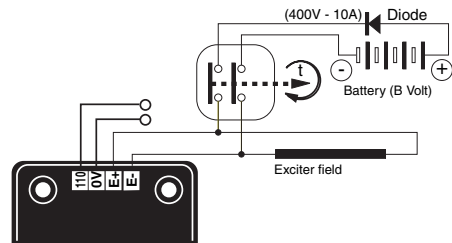

**Battery must be isolated from the earth.**



**Exciter field may be at line potential.**

# R230

## A.V.R.

### 3.3 - Electrical faults

| Fault  | Action   | Effect   | Check/Cause   |
|--|--|--|---|
| No voltage at no load on start-up  | Connect a new battery of 4 to 12 volts to terminals E- and E+, respecting the polarity, for 2 to 3 seconds | The alternator builds up and its voltage is still correct when the battery is removed.               | - Lack of residual magnetism  |
|  |  | The alternator builds up but its voltage does not reach the rated value when the battery is removed. | - Check the connection of the voltage reference to the AVR<br>- Faulty diodes<br>- Armature short-circuit   |
|  |  | The alternator builds up but its voltage disappears when the battery is removed                      | - Faulty AVR<br>- Field windings disconnected<br>- Main field winding open circuit - check the resistance   |
| Voltage too low  | Check the drive speed  | Correct speed  | Check the AVR connections (AVR may be faulty)<br>- Field windings short-circuited<br>- Rotating diodes burnt out<br>- Main field winding short-circuited - Check the resistance |
|  |  | Speed too low  | Increase the drive speed (Do not touch the AVR voltage pot. (P2) before running at the correct speed.)  |
| Voltage too high   | Adjust AVR voltage potentiometer   | Adjustment ineffective   | Faulty AVR  |
| Voltage oscillations   | Adjust AVR stability potentiometer   | If no effect : try normal / fast recovery modes (ST2)  | - Check the speed : possibility of cyclic irregularity<br>- Loose connections<br>- Faulty AVR<br>- Speed too low when on load (or U/F bend set too high)                        |
| Voltage correct at no load and too low when on load (*)  | Run at no load and check the voltage between E+ and E- on the AVR  |  | - Check the speed (or U/F bend set too high)  |
|  |  |  | - Faulty rotating diodes<br>- Short-circuit in the main field. Check the resistance<br>- Faulty exciter armature.   |
| <b>(*) Caution :</b> For single-phase operation, check that the sensing wires coming from the AVR are correctly connected to the operating terminals |  |  |   |
| Voltage disappears during operation  | Check the AVR, the surge suppressor, the rotating diodes, and replace any defective components             | The voltage does not return to the rated value.  | - Exciter winding open circuit<br>- Faulty exciter armature<br>- Faulty AVR<br>- Main field open circuit or short-circuited   |



**Warning : after operational testing, replace all access panels or covers.**

**R230**  
**A.V.R.****4 - SPARE PARTS****4.1 - Designation**

| Description | Type  | Code           |
|-------------|-------|----------------|
| A.V.R.      | R 230 | AEM 110 RE 014 |

**4.2 - Technical support service**

Our technical support service will be happy to provide any information you require.

When ordering spare parts, you should indicate the complete machine type, its serial number and the information indicated on the nameplate.

Part numbers should be identified from the exploded views and their description in the parts list.

Our extensive network of "service stations" can dispatch the necessary parts without delay.

To ensure correct operation and the safety of our machines, we recommend the use of original manufacture spare parts.

In the event of failure to comply with this advice, the manufacturer cannot be held responsible for any damage.

**R230**

## NOTES

**R230**

## NOTES

**R230**

## NOTES



**MOTEURS LEROY-SOMER 16015 ANGOULÊME CEDEX - FRANCE**

338 567 258 RCS ANGOULÊME  
S.A. au capital de 62 779 000 €

*[www.leroy-somer.com](http://www.leroy-somer.com)*